

Heat recovery and AAD process optimisation at Cog Moors WwTW

Dafydd Davies, Process Engineer

Introduction

- Background to the AAD Project at Cog Moors
- Anaerobic Digestion vs. Advanced Anaerobic Digestion
- Thermal Hydrolysis Process
 - Process Parameters
 - Benefits
- Cog Moors WwTW
- Options for Biogas Utilisation
- Combined Heat and Power
- Heat Recovery for Process Optimisation
- Summary





Background to project

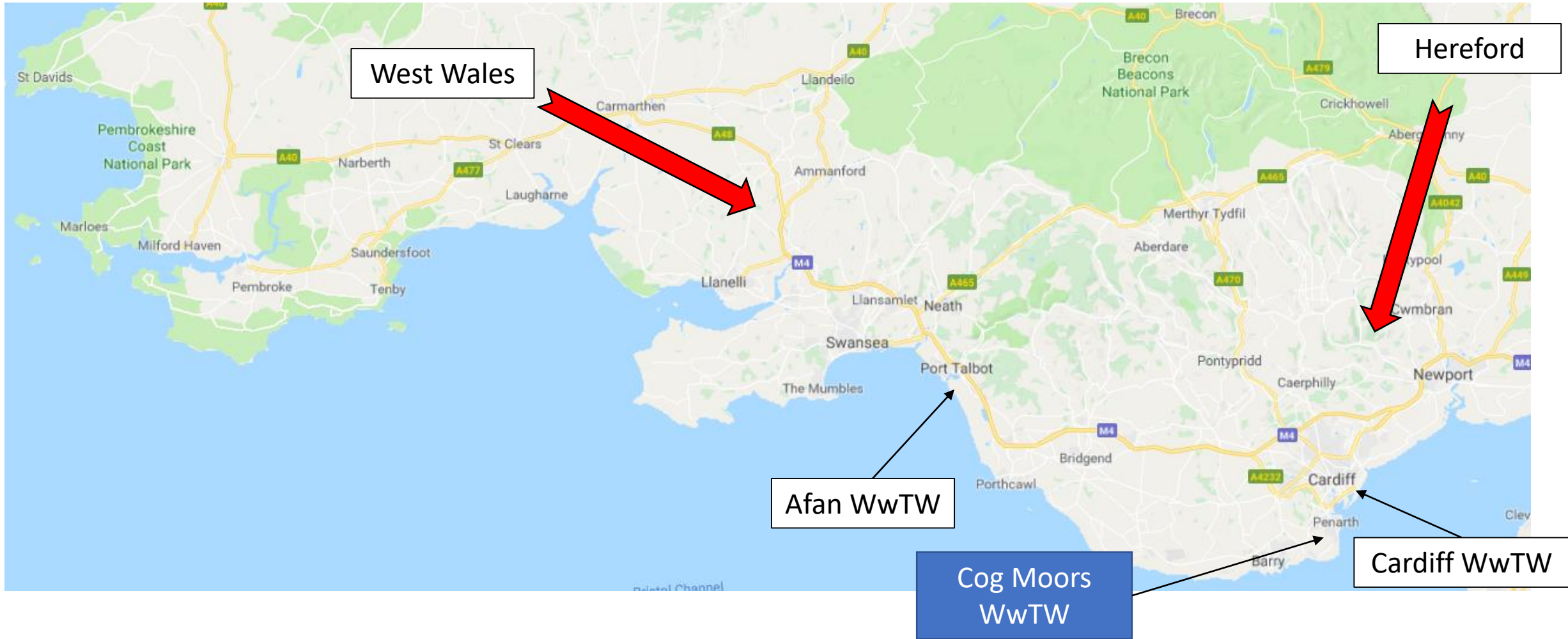

- All of South Wales and Hereford's sludge to be treated at an AAD site
- Currently only two AAD sites
- Need for a 3rd AAD site to deal with capacity – Cog Moors
- Design horizon - 2041

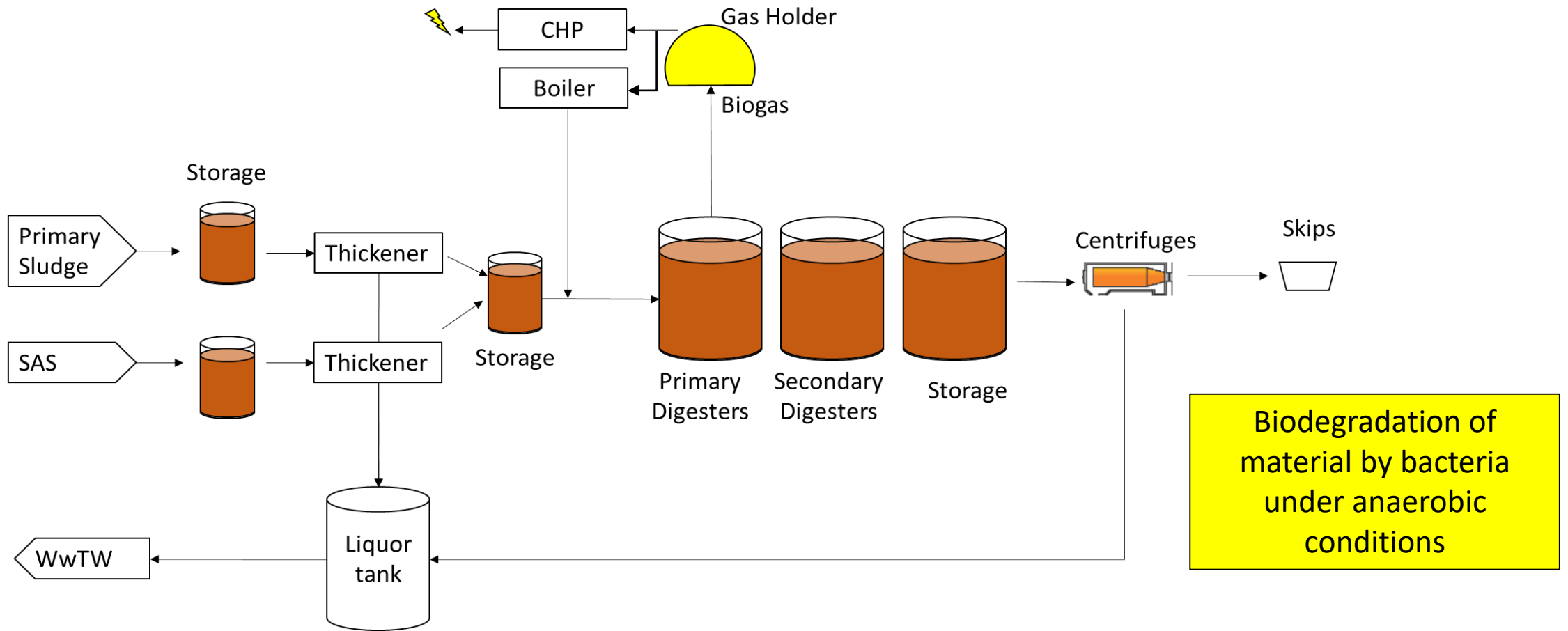

Anaerobic Digestion

Cog Moors currently has a conventional anaerobic digestion plant

Anaerobic Digestion

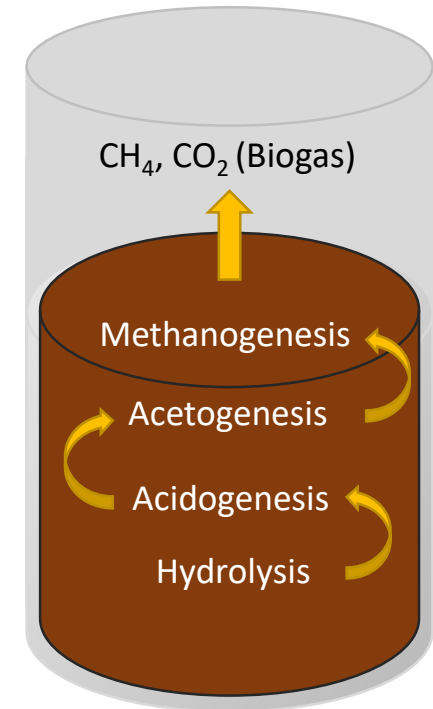
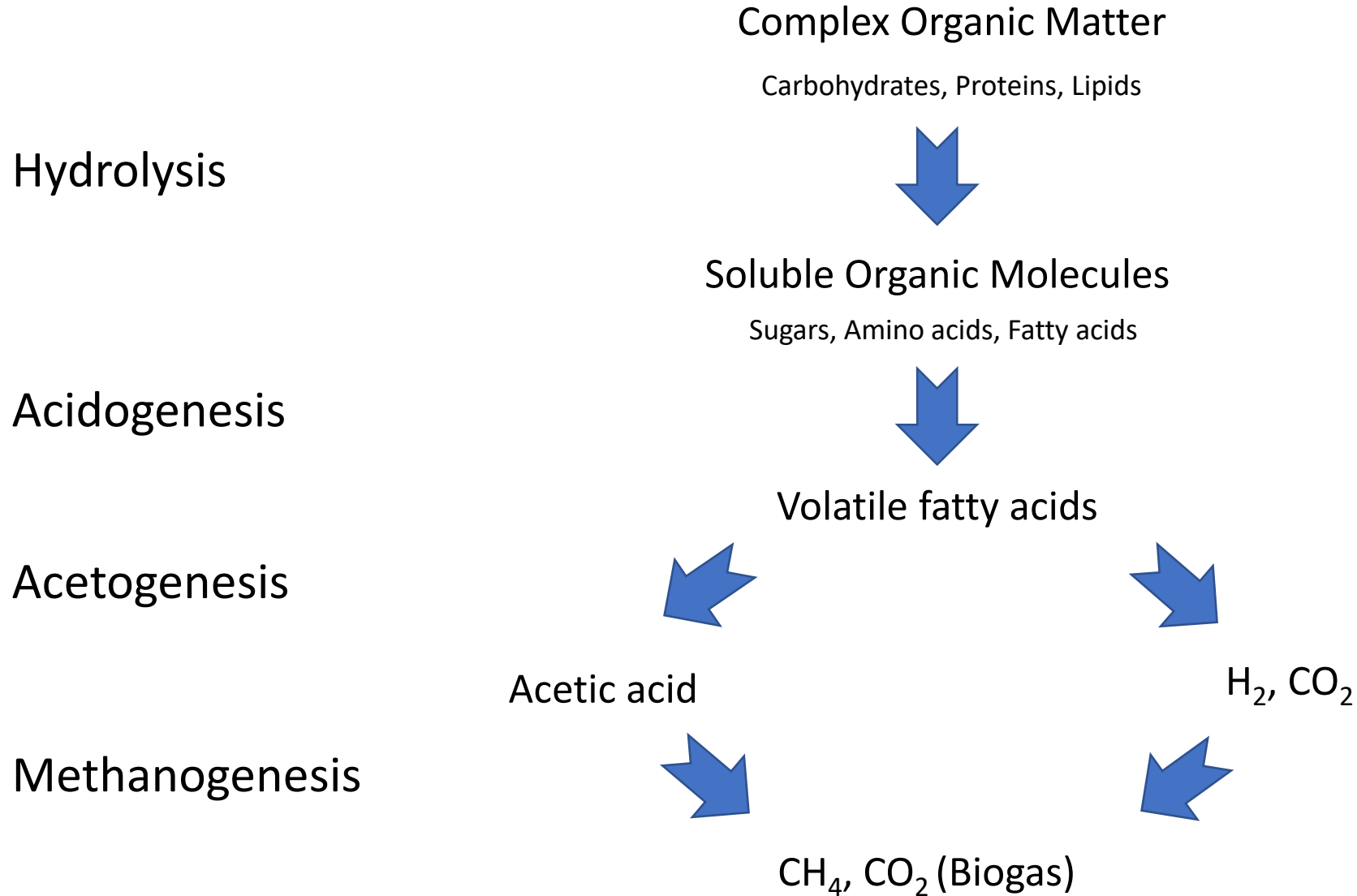

Anaerobic Digestion

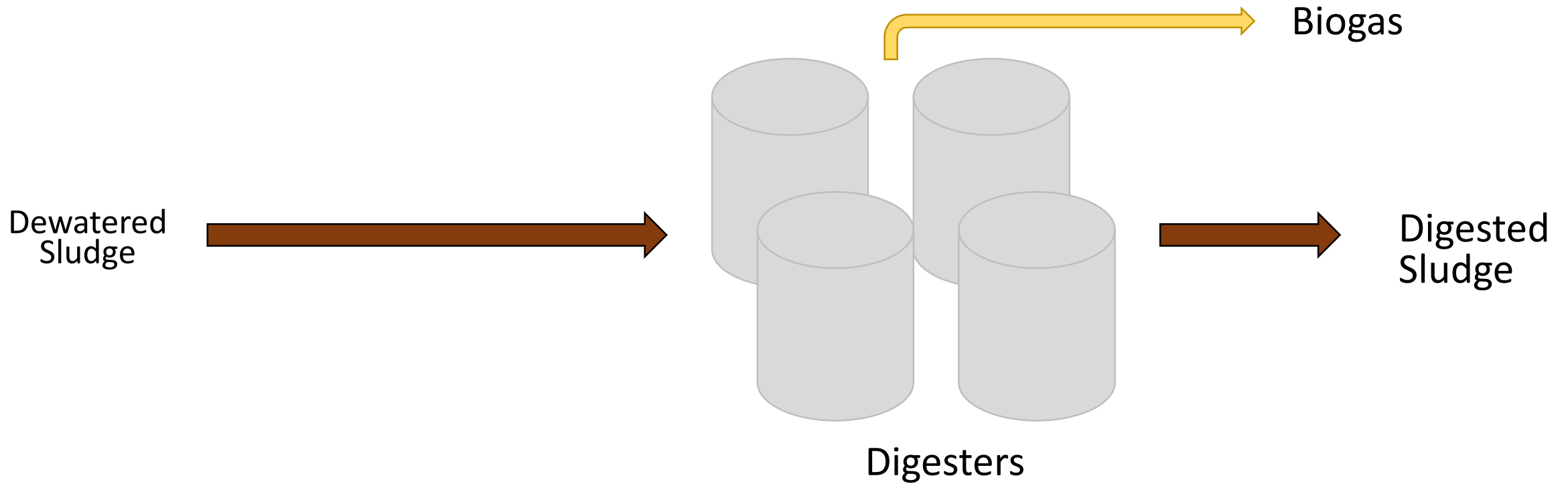

Advanced Anaerobic Digestion

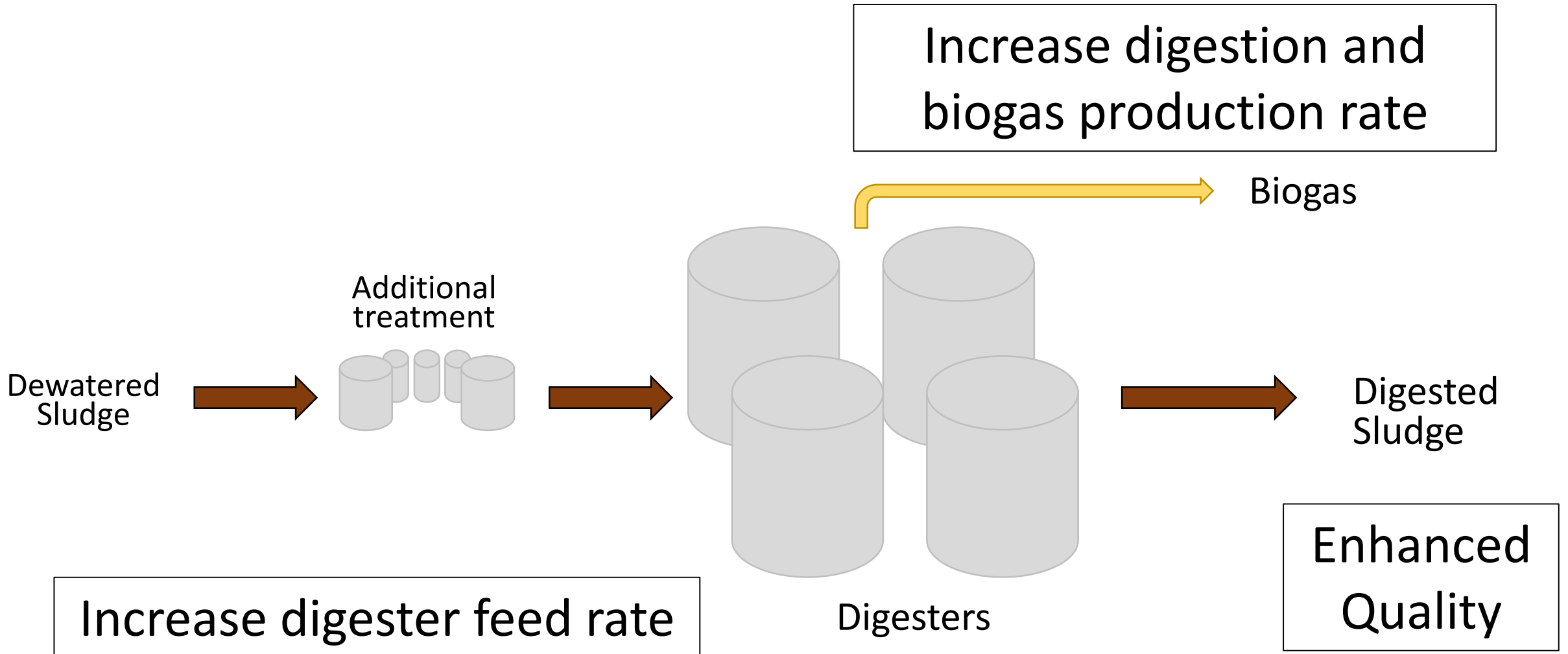







Thermal Hydrolysis Process

AAD Technology

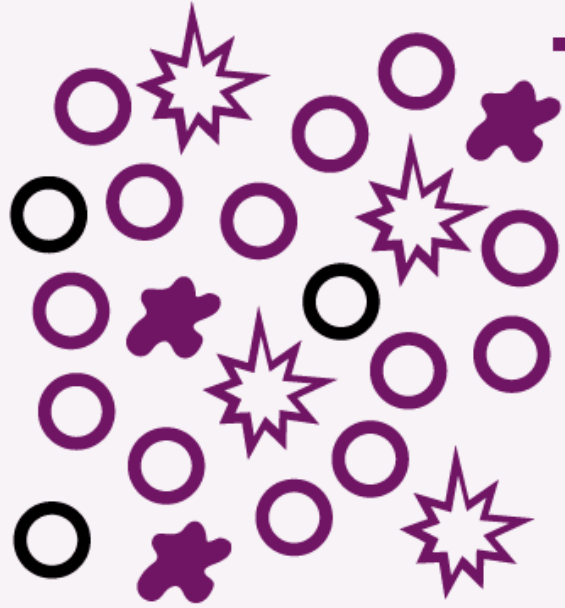
- Currently used at Cardiff and Afan
- Commonly used for AAD in UK
- Sludge treated with steam
- Held in a reactor at high temperature and pressure for a period of time
- Achieve Class A Sludge
- Depressurisation stage to rupture the biological cells and achieve pathogen free sludge
- Increase digestibility

RAW SLUDGE



-  Living bacteria
-  Dead bacteria
-  Inert suspended solids (SS)
-  EPS

THERMAL HYDROLYSIS

Raw sludge 16 - 17% DS

PULPER
Preheated to ~97° C, homogenized and reduction of viscosity. Retention time ~1.5 h

REACTOR
Batch process 165° C / 6 bar. Retention time 20 min.

FLASH TANK
Temp 102° C Retention time ~1.5 h

Reuse of steam

Process gases are cooled and compressed before sent to digesters to be broken down

Homogenized material 14 - 15% DS

Steam 11 bar





Hydrolyzed material 12 - 13% DS (1.5 - 2 bar)

Hydrolyzed material to digesters 8 - 12% DS

Dilution water

HYDROLYZED SLUDGE



-  Hydrolyzed SS
-  Cell content
-  Cell wall
-  Inert suspended solids (SS)
-  Hydrolyzed EPS

		AD	AAD (THP)
Feed Concentration	%ds	6	10
Volatile solids destruction	%	40	55
Sludge Quality	Class	B	A
Biogas Methane Content	%	55-65	60-70

AAD – Benefits

THP Process

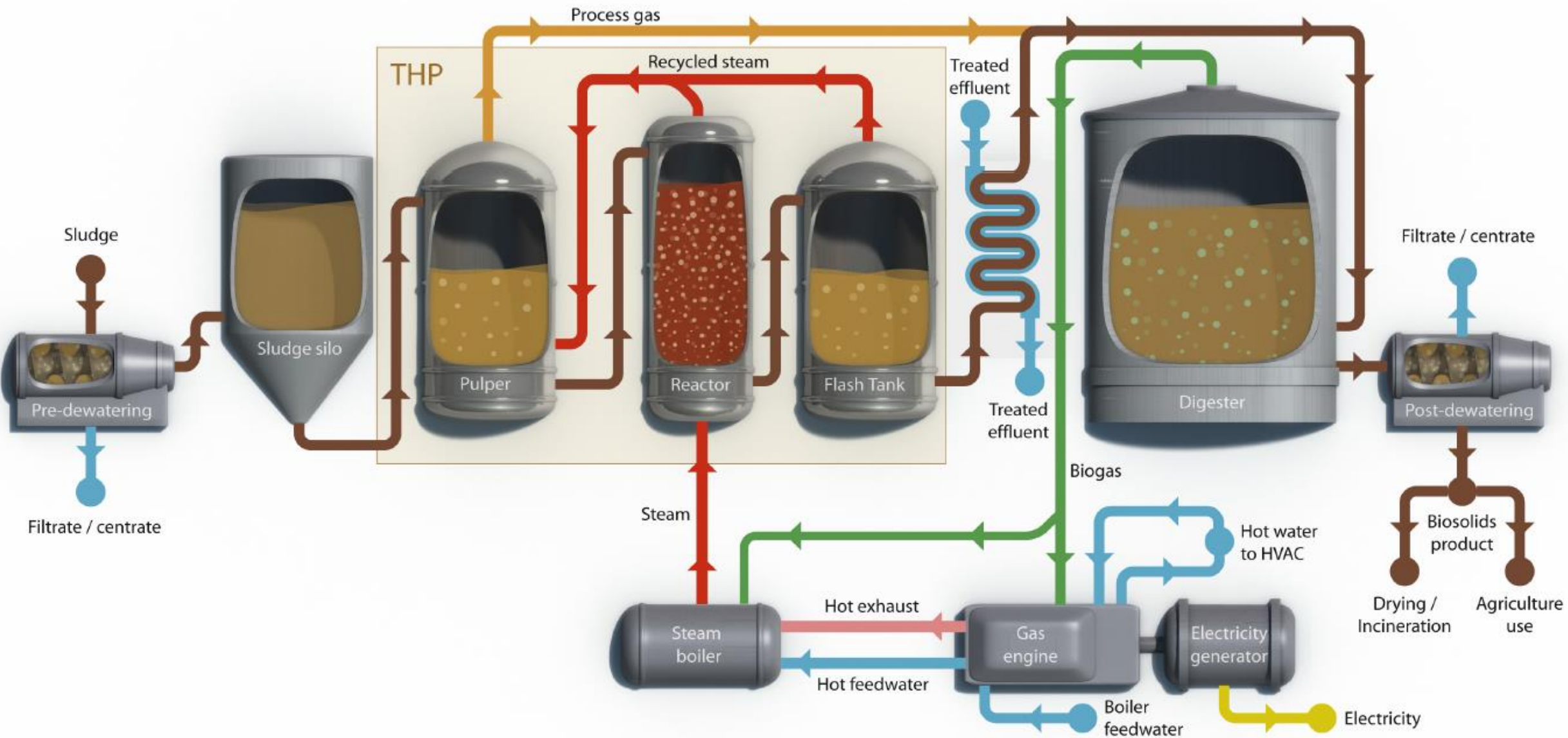

1. Dewatered Sludge (25%ds) transferred to THP feed silo

3. Sludge pre-heated by recycled stream in pulper and transferred to reactor

5. After 20-30 in reactor, sludge depressurised into the flash tank

6. Sludge diluted to 10%ds, cooled to 37°C and transferred to digester

7. Biogas produced and digested sludge is dewatered before being disposed of to land

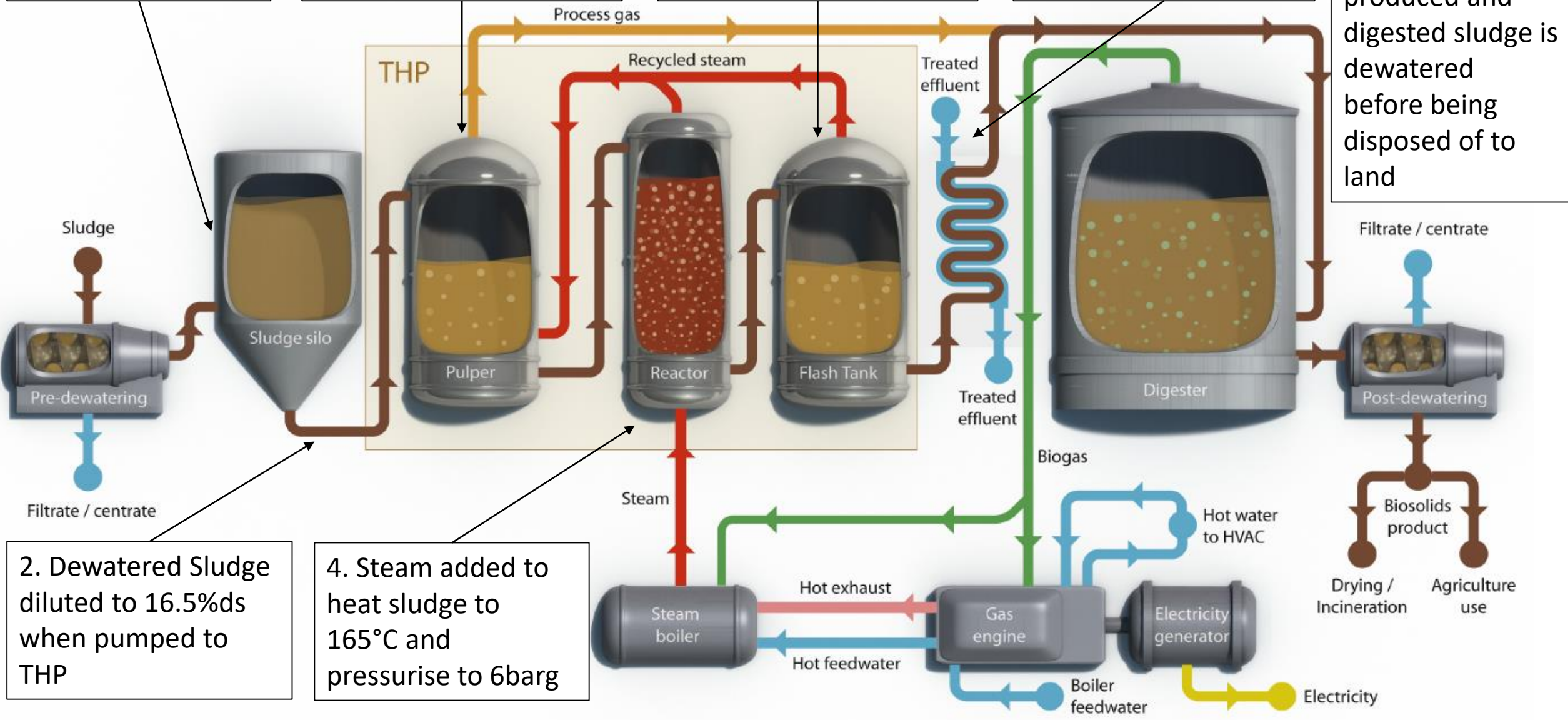

2. Dewatered Sludge diluted to 16.5%ds when pumped to THP

4. Steam added to heat sludge to 165°C and pressurise to 6barg

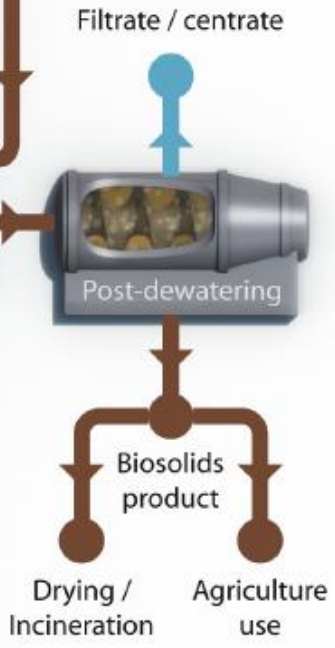
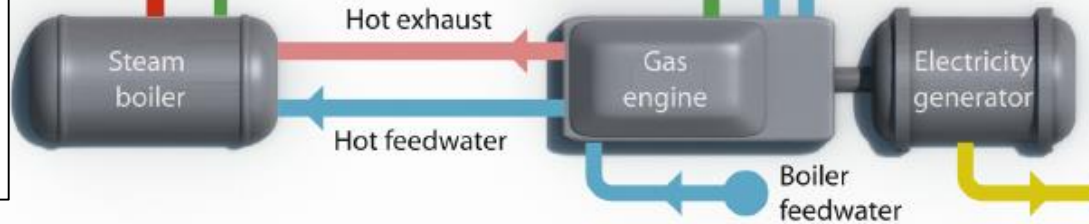

THP Benefits

No re-growth or re-activation

Better stability of sludge after digestion – high organic matter conversion

Pathogen kill rate – thermal treatment at 165°C for 20-30 minutes achieves elimination of all pathogens

1. Class A Sludge

Reduce risk associated with decreasing land bank availability for sludge disposal – Class A

Eliminating the need for lime to be used to achieve the advanced quality of sludge

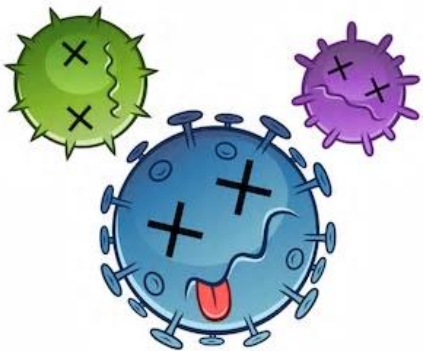

THP Benefits

Better dewaterability of THP digested sludge

Less polyelectrolyte required – 20% reduction

Better solids destruction in digesters – 50-60% VS destruction

2. Decrease Volumes of Sludge

Disposal volumes and transport costs lowered. 40% reduction



THP Benefits

230% increase compared to conventional AD

Increase in power production

Increase in biogas production

3. Contribute to long-term vision of energy neutrality

Savings/income from power

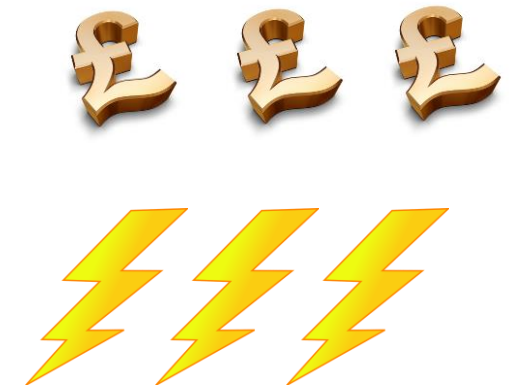
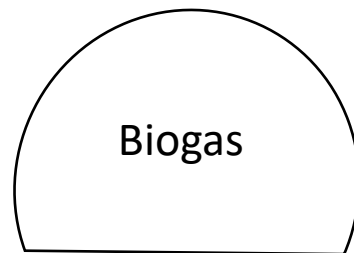
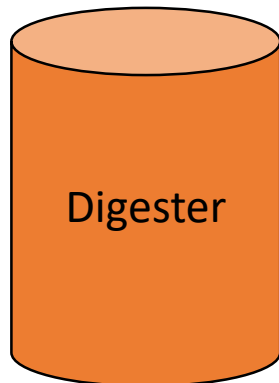

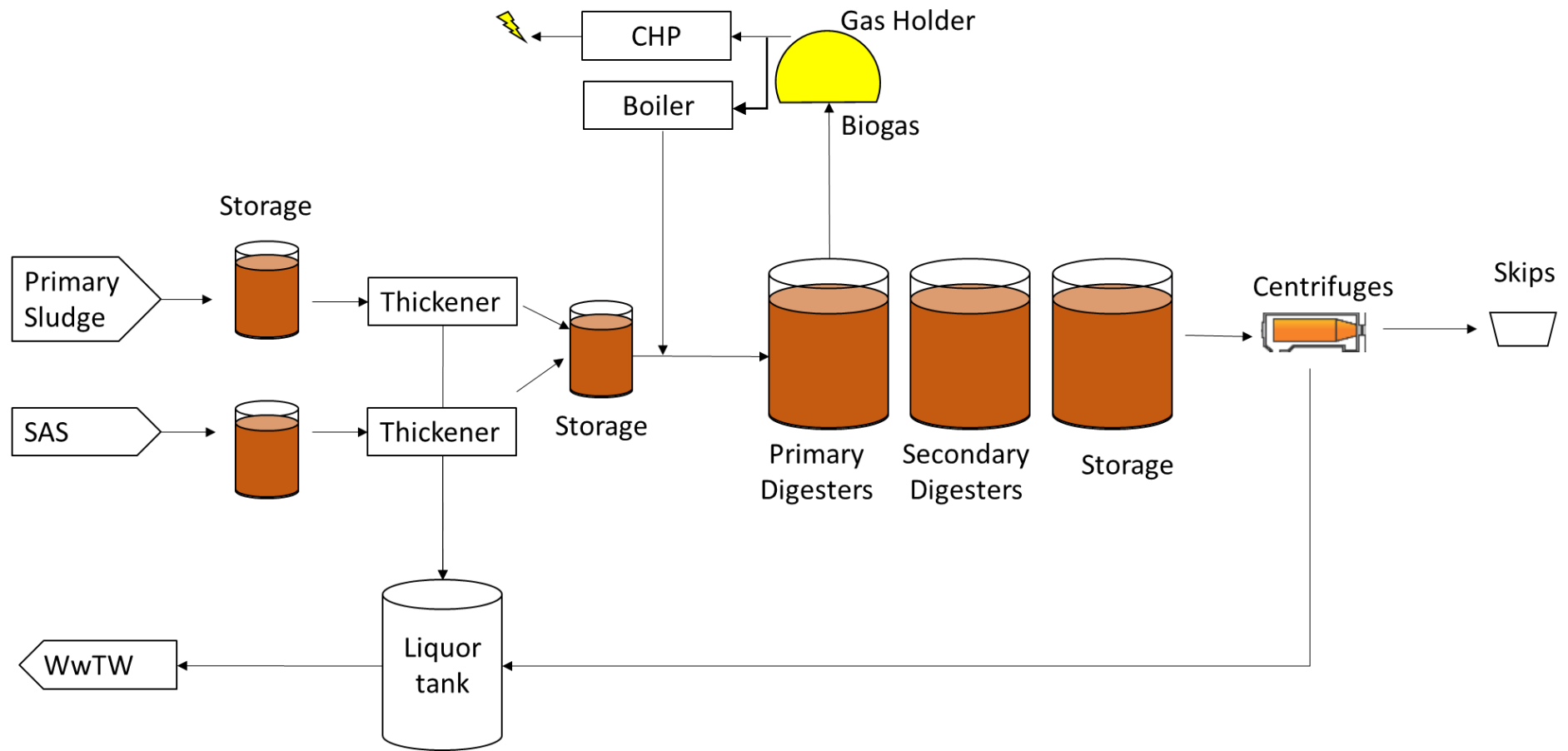

Cog Moors - Current

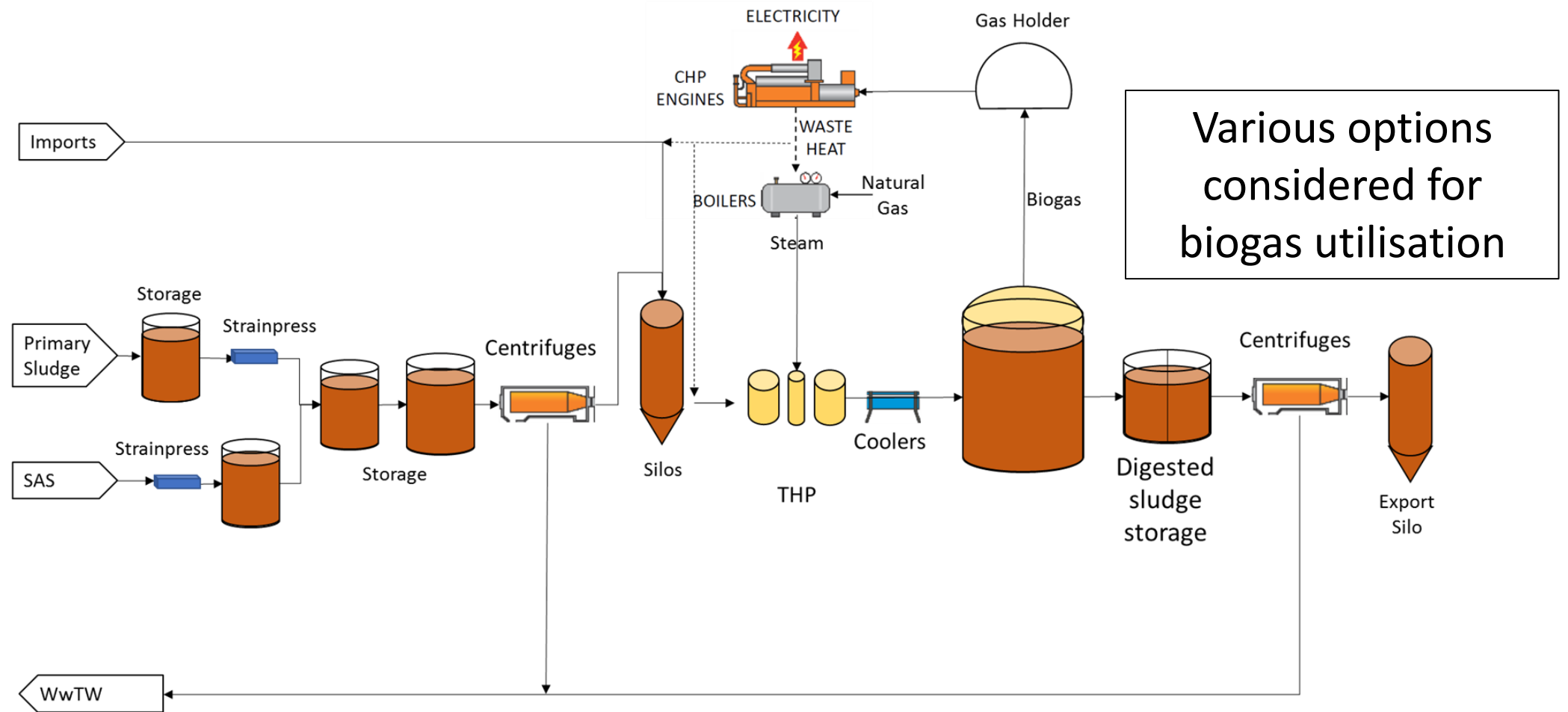

Various options considered for biogas utilisation

Cog Moors – Future AAD Site

1. Combined Heat and Power (CHP)

- Biogas from the anaerobic digesters used to produce electricity
- Off-set the purchase of electricity to power the WwTW
- Export electricity during periods of lower on-site power demand
- Receive income from exporting electricity
- Waste heat can be recovered for beneficial use on site



2. Gas to Grid



- Gas exported to the network for income (such as at Five Fords WwTW)
 - Income from natural gas supplier
 - Renewal Heat Incentive (RHI) - government initiative to encourage the production of gas from renewable sources
- Biogas not beneficially re-used on site
- No electricity exported as no engines required
- Limited to capacity of the network
- Gas needs to be purified to methane only (Removal of $\text{CO}_2/\text{H}_2\text{S}/\text{N}_2$)
- Propane added to achieve minimum calorific value
- Compression station may be required depending on location and pressure of grid

3. Fuel Cell

- Generates both electricity and waste heat from biogas
- Off-set the purchase of electricity to run WwTW
- Excess power can be exported to the grid for income
- Waste heat beneficially used on site
- Biogas must first be converted to hydrogen to run the fuel cell
- Yet to be a full-scale or even a pilot-scale application at a UK WwTW



WLC Analysis

Income Streams/OPEX Benefits	CHP	Fuel Cell	Gas to Grid
Biomethane Income			✓
Electricity Income	✓	✓	
Electricity Saving on Site	✓	✓	
Natural Gas Saving on Site	✓	✓	
Renewables Obligation Certificates (ROCs)	✓	✓	
Enhanced Capital Allowance	✓	✓	
Business Rate Exemption	✓	✓	
Renewable Heat Incentive		✓	✓
Climate Change Levy Exemption		✓	

WLC Analysis

Income Streams/OPEX Benefits	CHP	Fuel Cell	Gas to Grid
Biomethane Income			✓
Electricity Income	✓	✓	
Electricity Saving on Site	✓	✓	
Natural Gas Saving on Site	✓	✓	
Renewables Obligation Certificates (ROCs)	✓	✓	
Enhanced Capital Allowance	✓	✓	
Business Rate Exemption	✓	✓	
Renewable Heat Incentive		✓	✓
Climate Change Levy Exemption		✓	

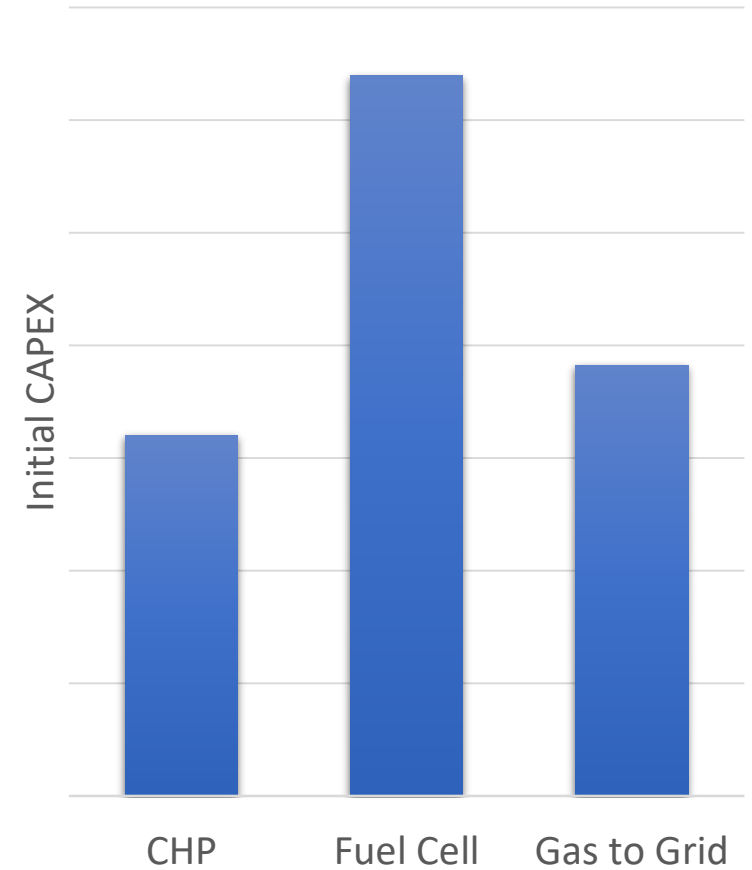





CHP Selected after WLC Analysis

- Big saving on electricity/heat usage
- Can connect CHP to grid
- Income from exports
- G2G has a higher OPEX for cleaning biogas to biomethane
- Fuel Cell tariffs low compared to other options
- Fuel cell unproven technology and has a high CAPEX



Combined Heat and Power (CHP)

-  heated water
-  low temperature hot water
-  air
-  biogas
-  exhaust

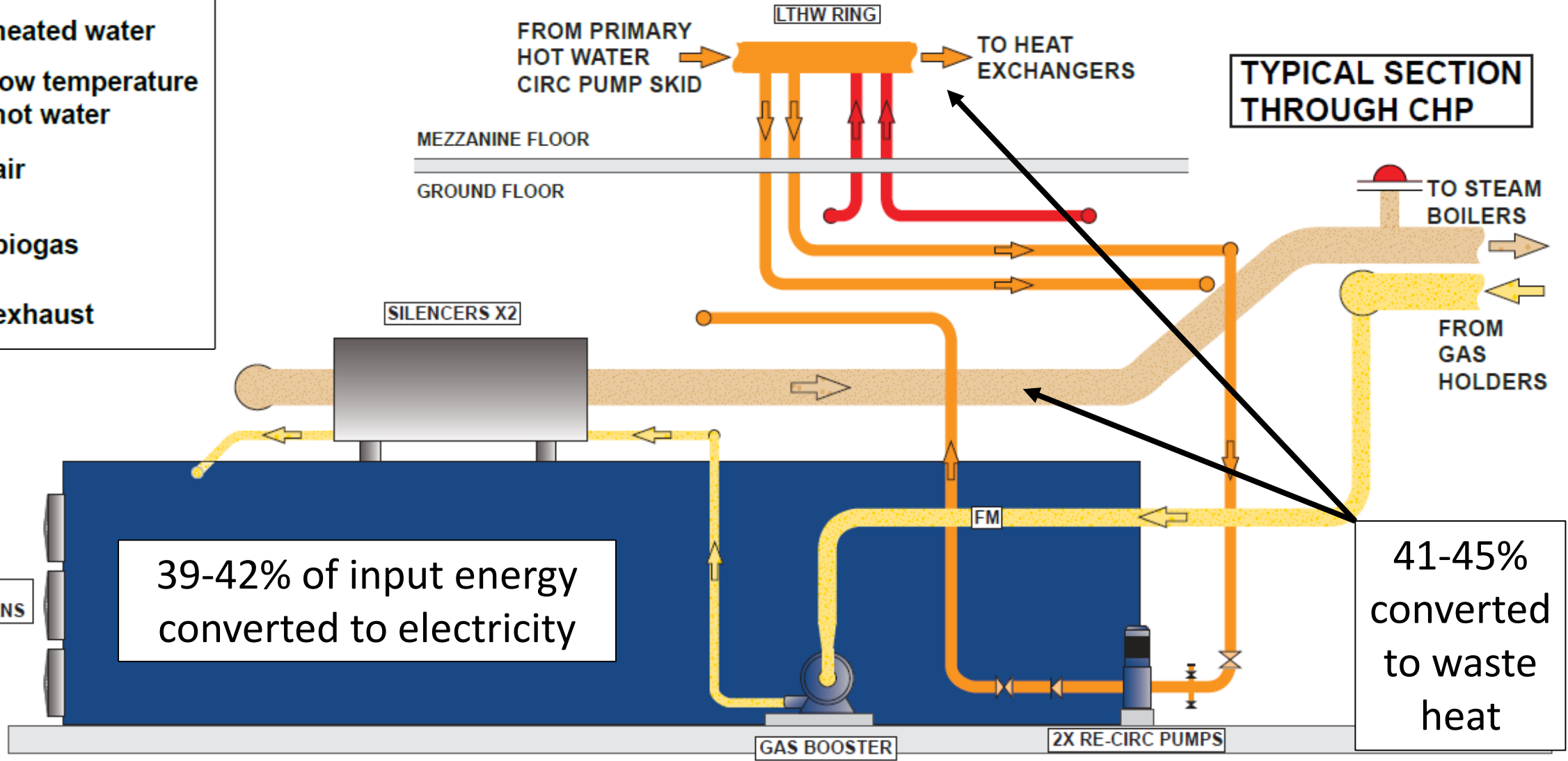

Energy Neutrality

Save buying electricity at 10p/kWh

Income of 4.5p/kWh

Biogas produced by digesters

Biogas powers CHP engines

Electricity generation powers site

Excess power exported to grid for income

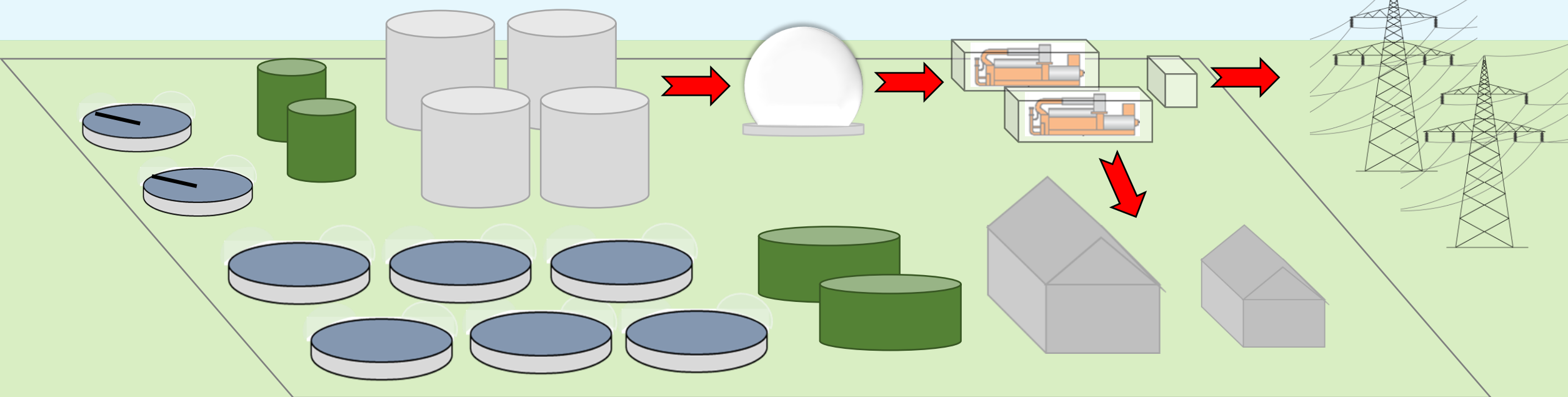

Heat recovery from CHP Exhaust and Low Temperature Hot Water

- Engines also produce a lot of useful waste heat
- Off-set natural gas burned in the boilers that produces steam for the THP



Heat Recovery

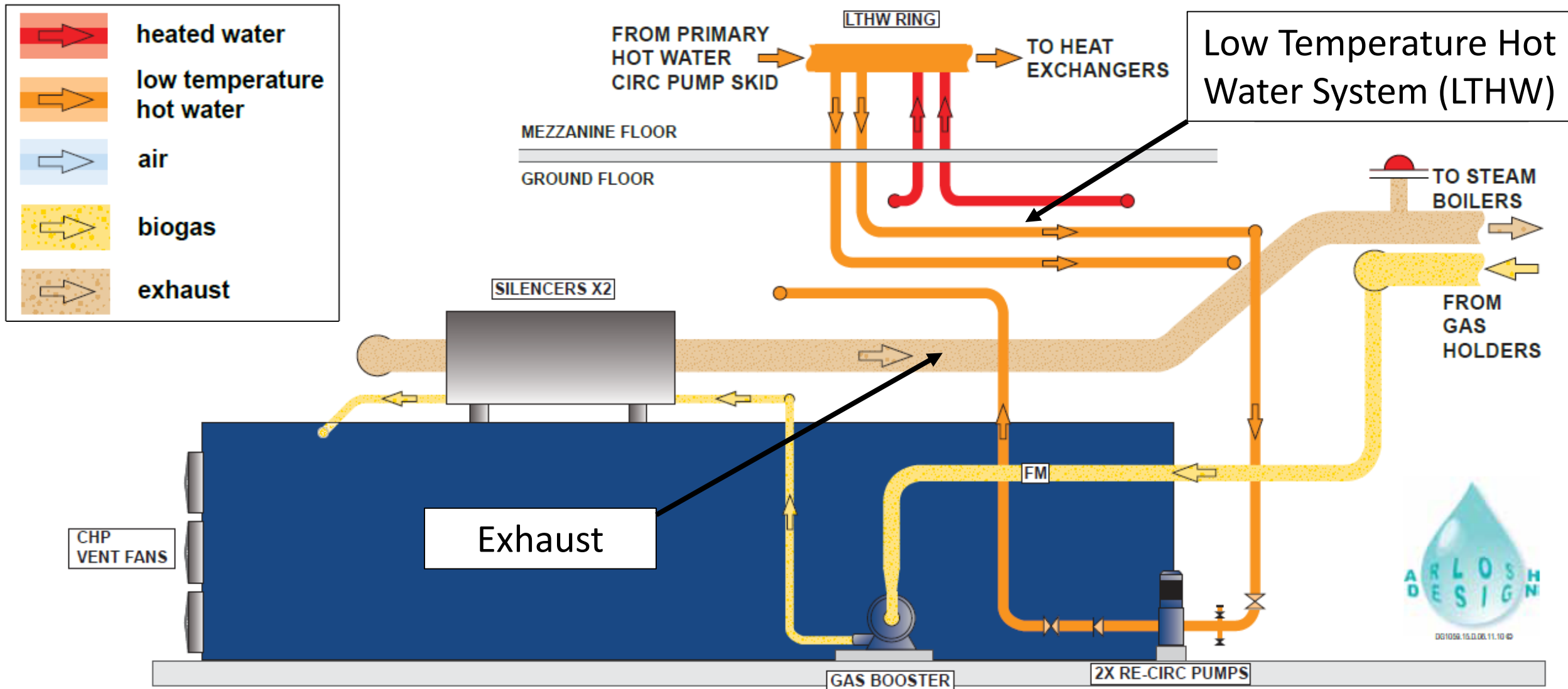

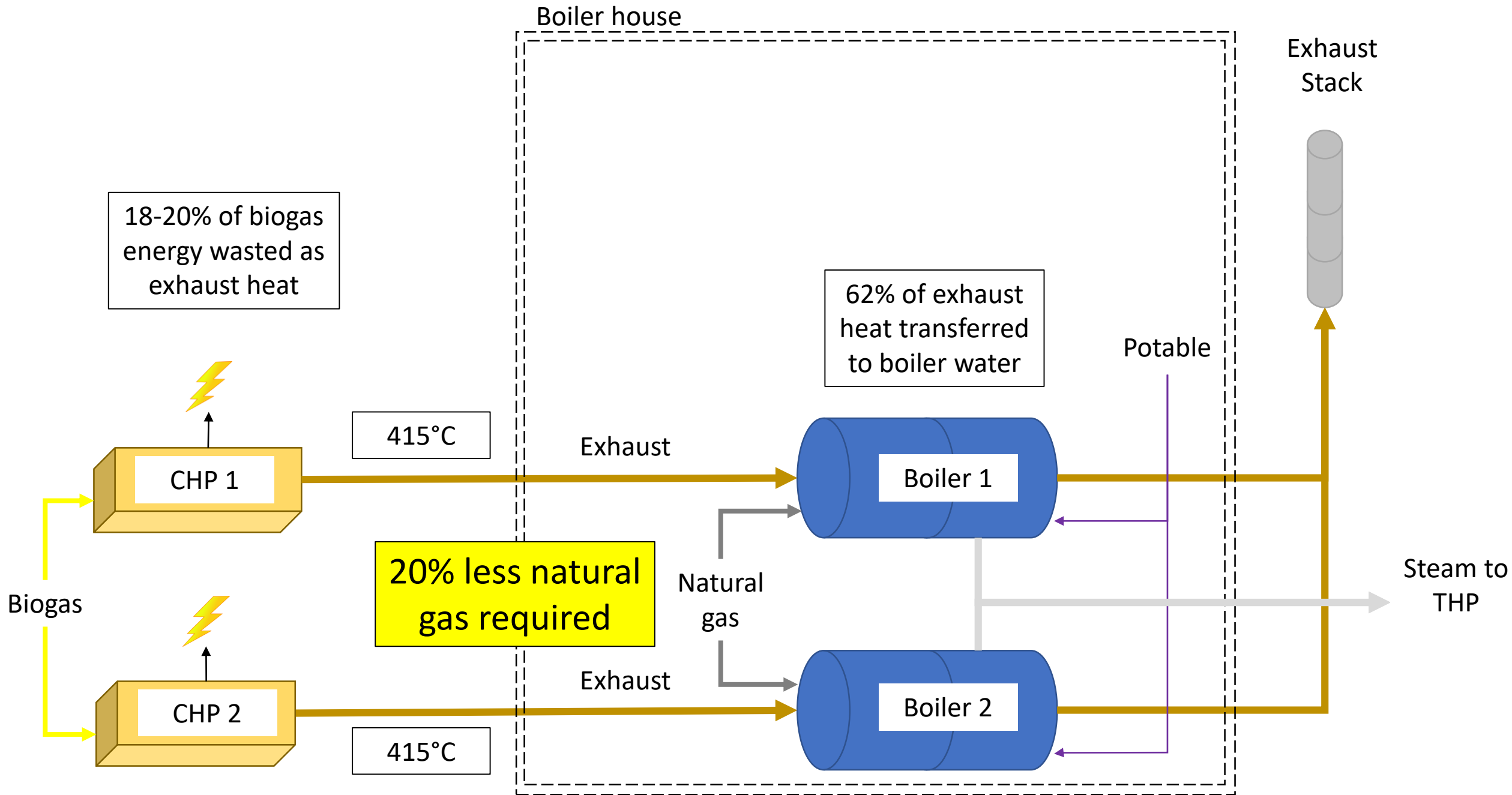

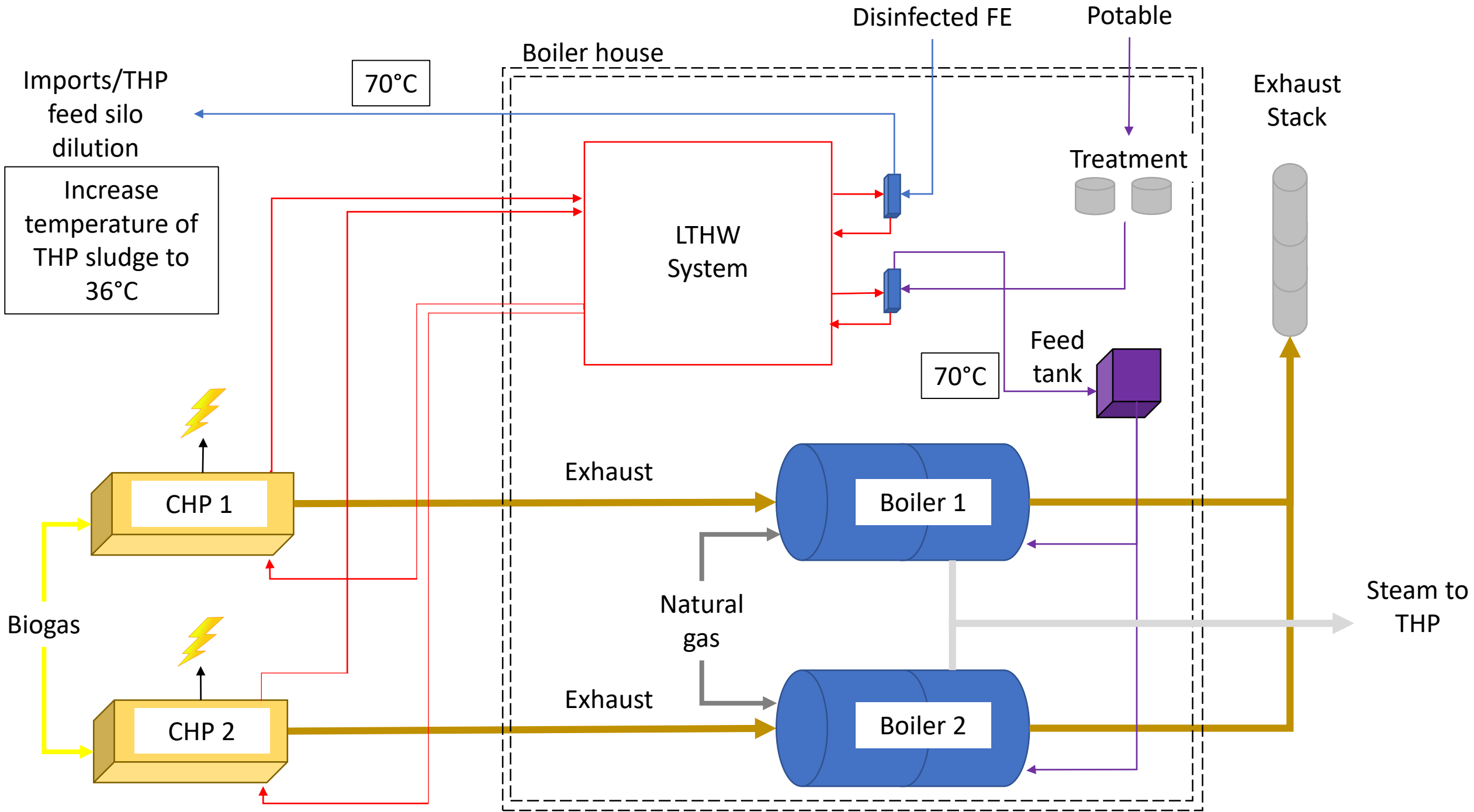

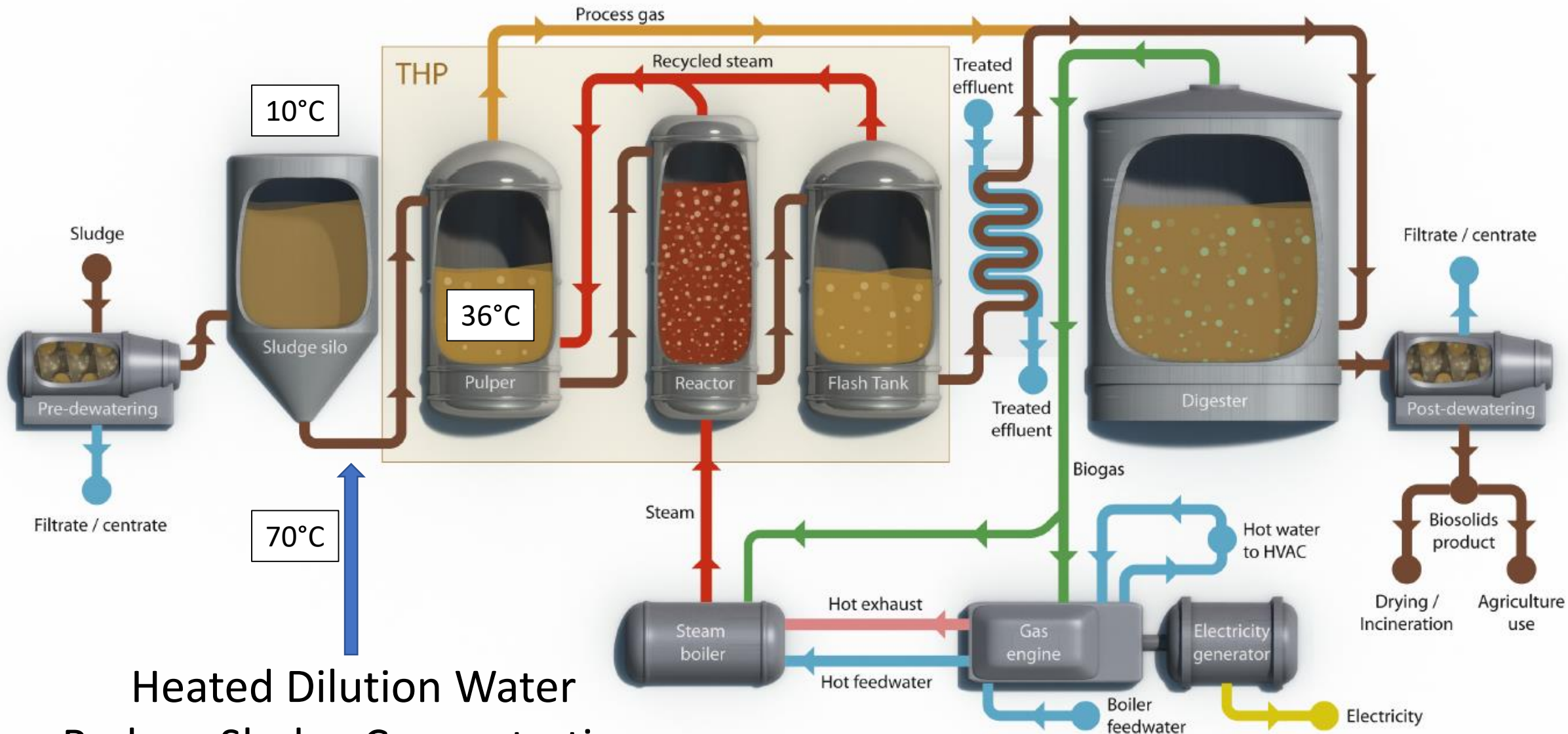

Heated Dilution Water
 Reduce Sludge Concentration
 25% → 16.5%

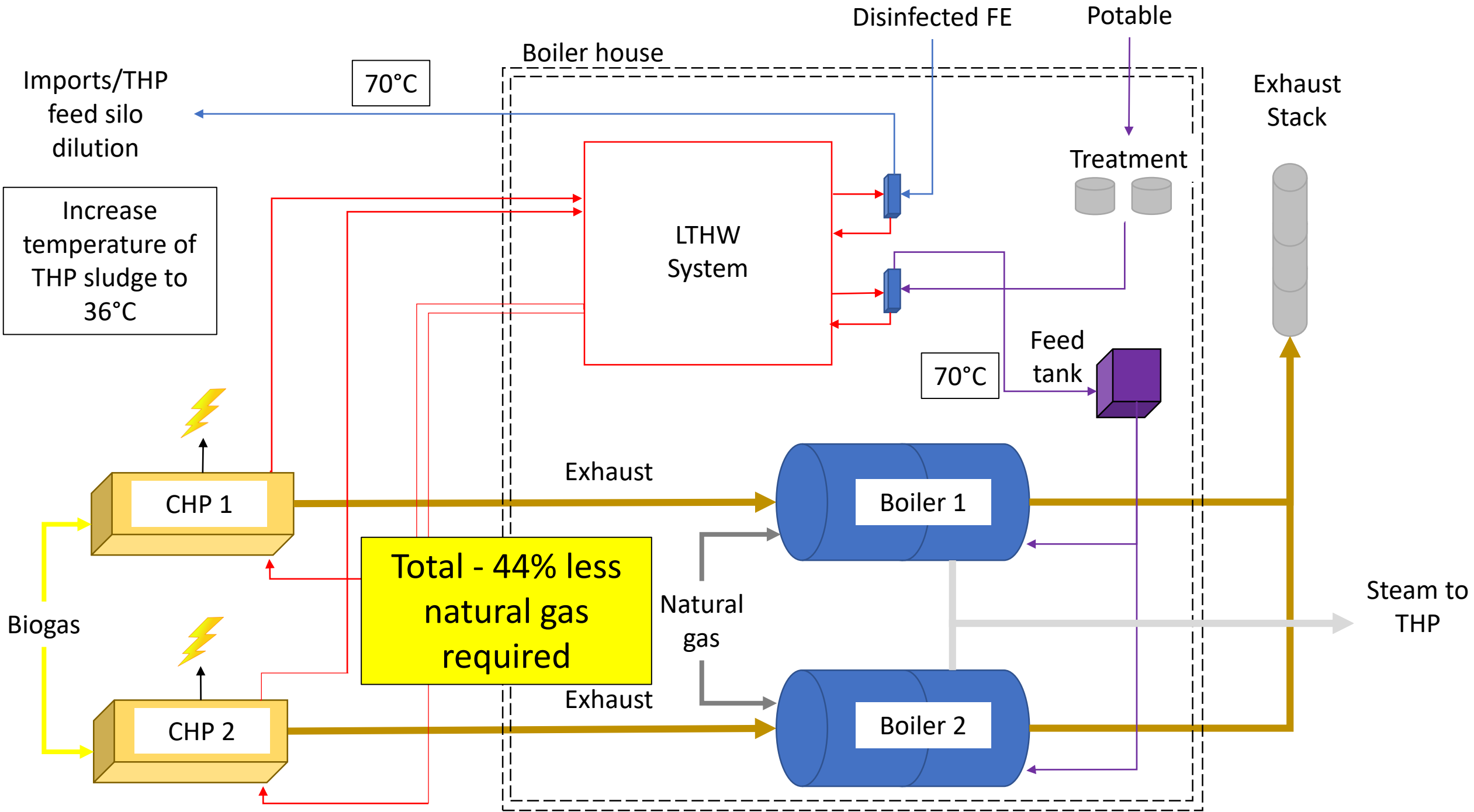

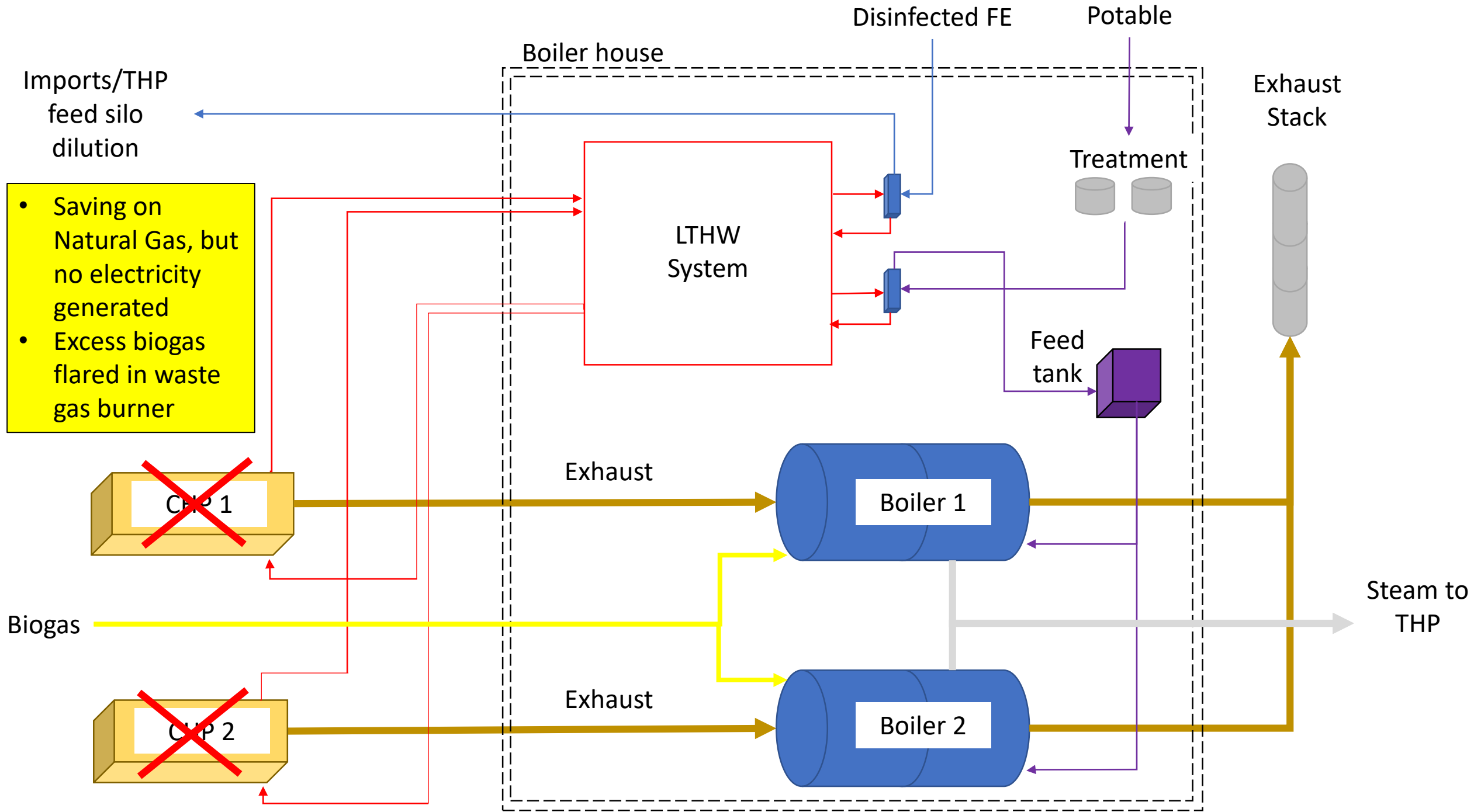

Summary

- Background to Cog Moors Project
- Anaerobic Digestion vs. Advanced Anaerobic Digestion
- Thermal Hydrolysis Process
- Options for Biogas Utilisation
- Combined Heat and Power
- Heat Recovery for Process Optimisation

Questions?

